

MOBILE DRY BATCH READY MIX PLANT

- 1. MOBILE BATCH UNIT
- 2. MOBILE 80TON SILO'S (12m HIGH CUBE CONTAINER)
- 3. CONTROL CABIN
- 4. STORE / WORKSHOP

STANDARD FEATURES :

- COMPLETE PLUG AND PLAY ELECTRICAL SYSTEM
- FULLY AUTOMATED BATCHING SYSTEM

OPTIONAL

- GENSET AND FLOW BINS
- 50KG / 2TON BAG BREAKING STATIONS
- 2 X SUPERLINKERS

BENEFITS OF A METATE CONTAINERISED PLANT

- NO CONCRETE FOUNDATION REQUIRED
- NO ELECTRICIAN REQUIRED
- EASY TO TRANSPORT, 3X NORMAL TRUCKS
- EASY TO SET UP. CAN BE DONE IN 1 DAY
- ALL YOU NEED IS A WATER SUPPLY, LEVELED AND COMPACTED GROUND FOR PLANT FOOTPRINT

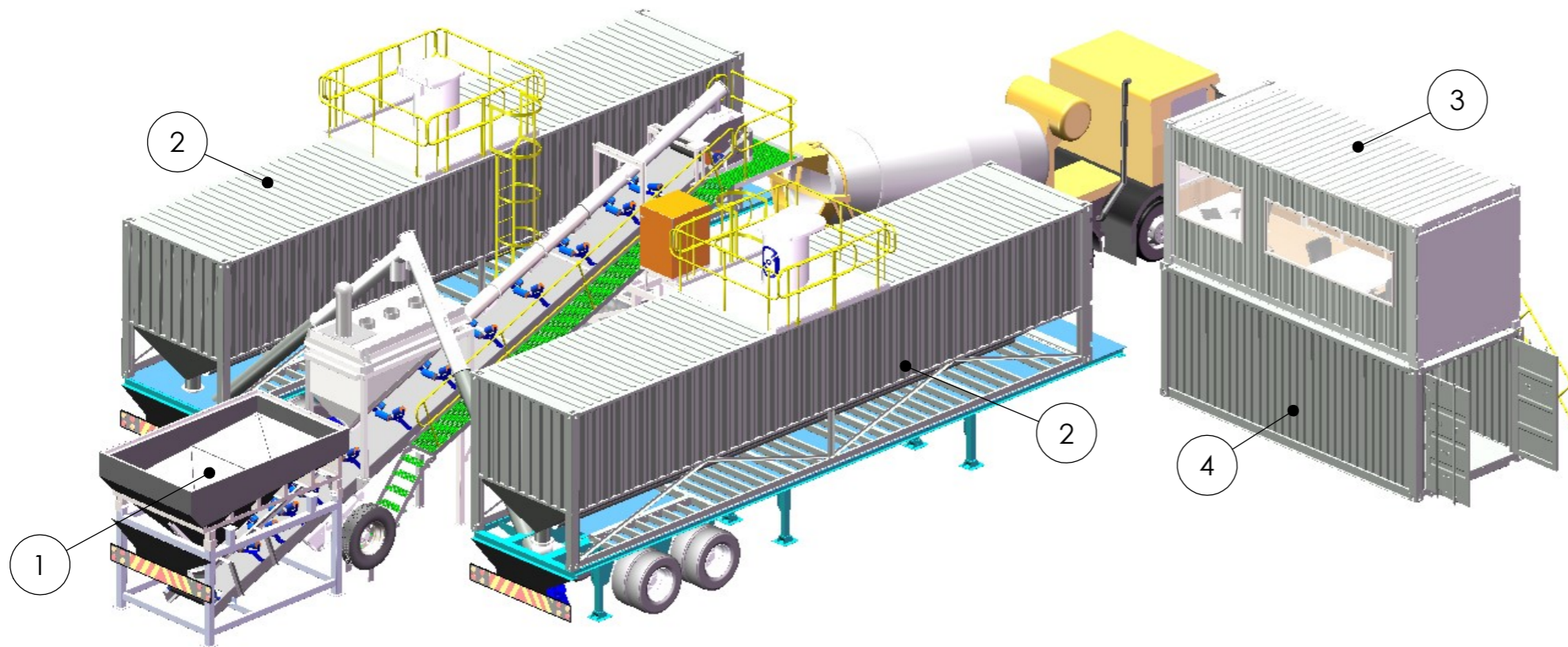
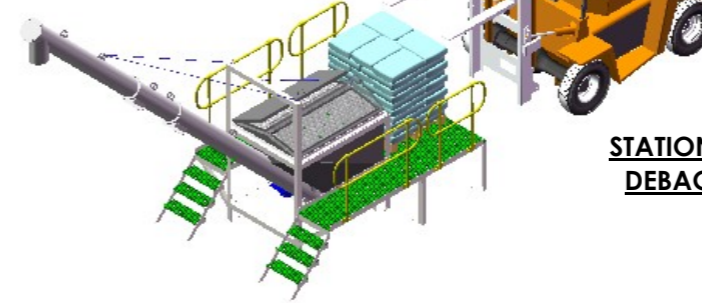
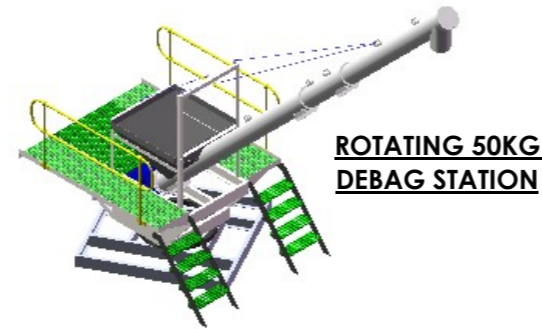
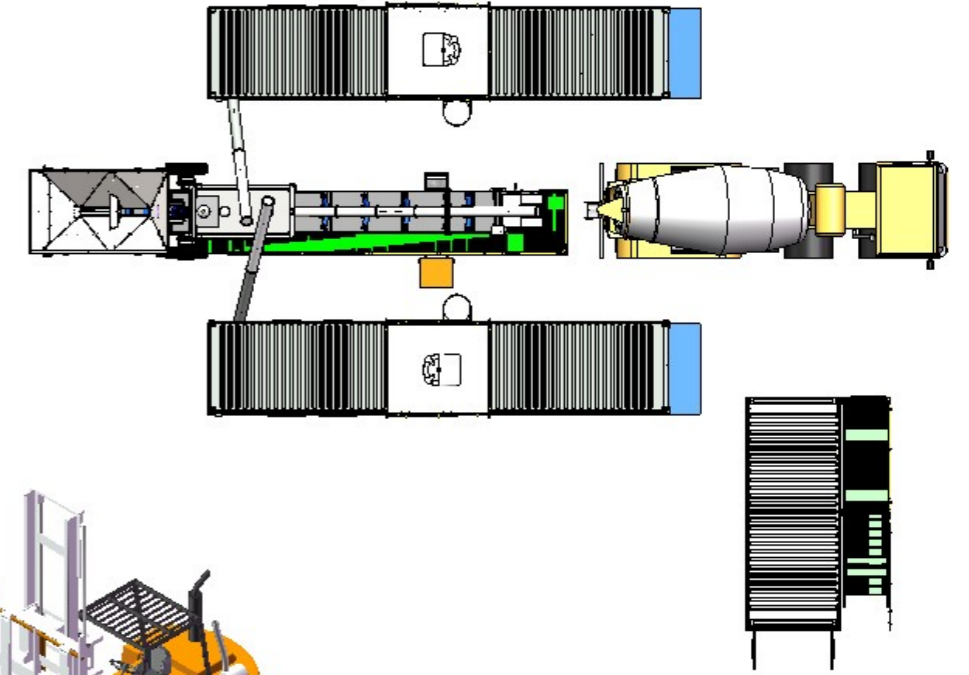
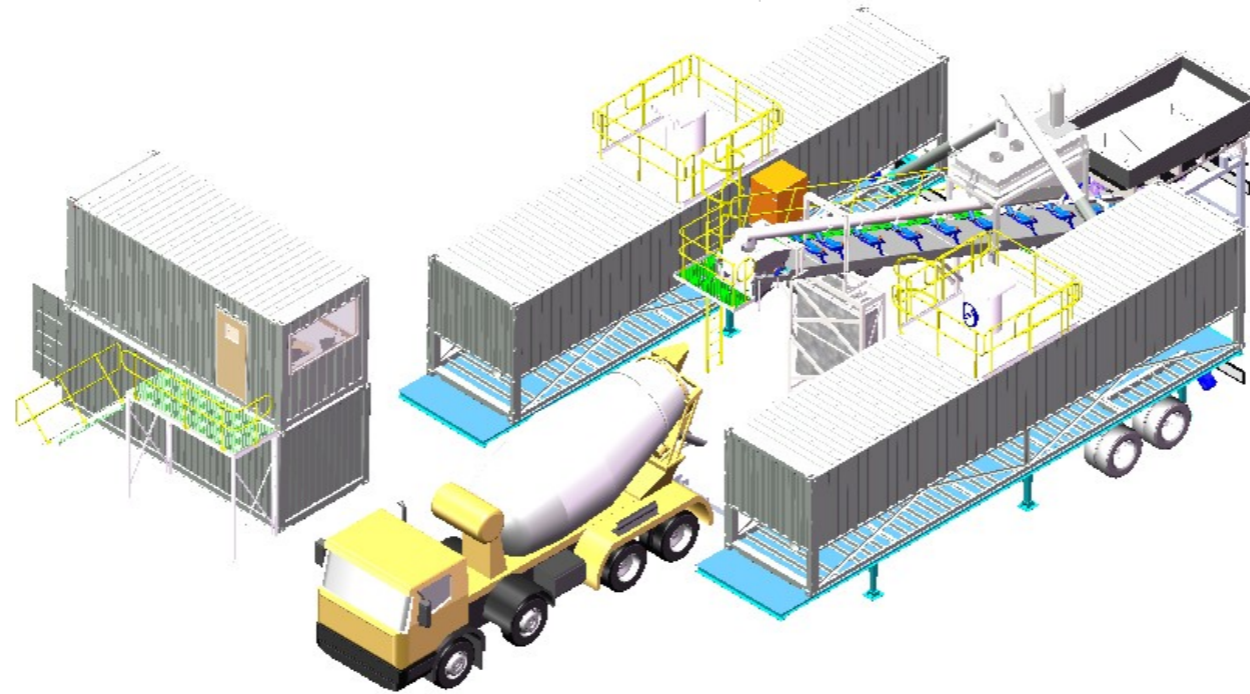

REV	DESCRIPTION	DATE	INITIAL
METATE			
TITLE FULLY MOBILE PLANT PROPOSAL			
DRAWING NO.			
CAD FILE	SCALE	SHEET 1 of 1	SIZE A3
THE INFORMATION CONTAINED IN THIS DRAWING IS THE SOLE PROPERTY OF METATE CONSTRUCTION EQUIPMENT ANY REPRODUCTION IN PART OR WHOLE WITHOUT THE WRITTEN PERMISSION OF METATE CONSTRUCTION EQUIPMENT IS PROHIBITED.			